

THIS DESIGN IS THE PROPERTY OF BROWNELL LTD. AND MAY NOT BE COPIED OR REPRODUCED WITHOUT THEIR PRIOR WRITTEN PERMISSION.

DRG. No.	
BL/D 4210 INST.	
USED ON	
ISSUE	ALTERATION
A	26.2.85
B	4.0 WAS 2.0 MOD No. 3032 26.2.86
C	MOD No. 3080 16.6.86
D	FLATNESS TOL. ADDED MOD No. 3763 20.10.89
E	REFILL PT. No. CHANGED MOD No. 3844 16.5.90
F	NSN ADDED MOD No. 5975 31.7.02

THIRD ANGLE PROJECTION

REMOVE ALL SHARP EDGES UNLESS SPECIFIED.

DO NOT SCALE - ASK.

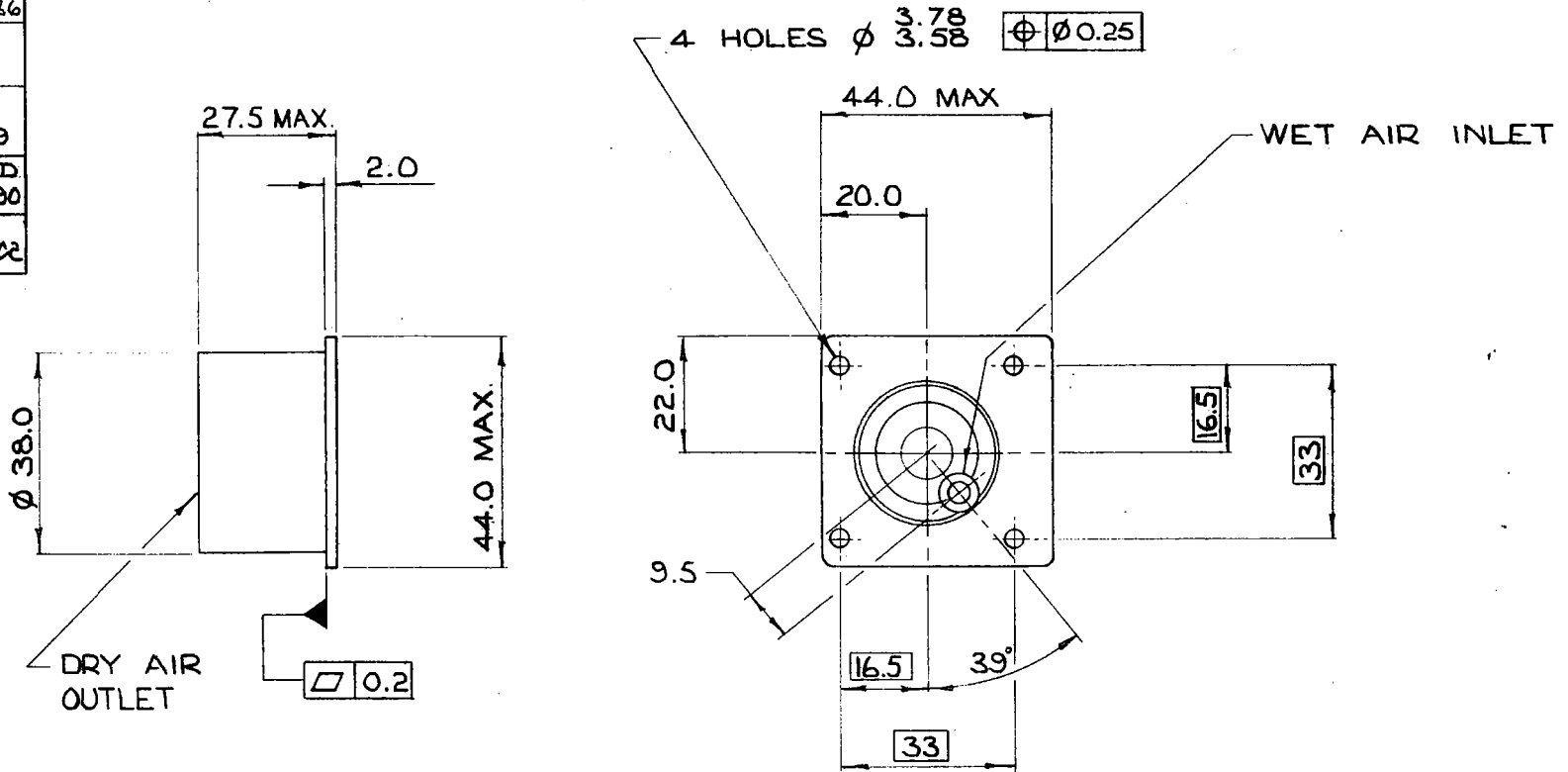
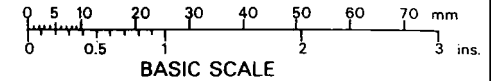

NOTES

1. FILLED WITH MOLECULAR SIEVES DESICCANT
2. PACKAGED FOR A SHELF-LIFE OF 5 YEARS
3. THE FOLLOWING ITEMS ARE SUPPLIED WITH THE DESICCATOR :-
 - I/ HUMIDITY INDICATOR DISC - PT.No. BL/D 4454
 - II/ BACKING DISC - PT.No. BL/D 4455
 - III/ R.F. SCREEN - PT. No. BL/D 4456
4. REFILL PT. N. BL/D 4567

MATERIAL	PROTECTIVE TREATMENT	TOLERANCES UNLESS STATED	BROWNELL LTD. LONDON, N.W.10.	CUSTOMERS REF.	DRAWN	CHECKED
ALUM. ALLOY	ALOCROM 1200 D.STAN 03-18/1	± 0.25		TITLE 4440-99-577-3326 DESICCANT CONTAINER DEHUMIDIFIER (AFT - BODY)		JA
EST. WT.		DIMNS. IN mm /m.m.		DRAWING No.	BL/D 4210 INST.	
		SCALE (ORIGINAL) 1/1				