

**Selection Guide**

The data shown below should be used to assist in the selection of the most suitable unit for a particular application.

1. Select a model which has a flow rate that is greater than the maximum filling rate or the maximum discharge rate of the pump which empties the tank.
2. Decide upon the period of time (usually in months) you wish to allow between changes of desiccant in the dryer. Calculate the volume of liquid which will be drawn from the tank during that period. Select a model which will give you a capacity greater than the calculated volume.
3. The unit which should be used will be the larger of the models from the results of 1 and 2 above.

Flow Rate/Capacity Chart						
MODEL		605	610	615	620	630
Maximum Filling or Emptying Rate	m ³ /hr	24.6	28.9	62.9	114	250
	litres/min	410	480	1048	1897	4136
	c.f.m	14.5	17	37	67	147
	imp.galls/min	90	206	230	417	916
Maximum Fluid Capacity Related to Desiccant Content	m ³	9	55	125	225	500
	litres	9000	55000	125000	225000	500000
	ft ³	318	1975	4431	7930	17658
	imp.galls	1981	12297	27593	49387	109972
Replacement Desiccant Charge Data	wt. of spare charge	3.3 Kg	10.75 Kg	20.0 Kg	35.0 Kg	67.0 Kg
	wt. of desiccant	1.4 Kg	5.6 Kg	12.5 Kg	22.4 Kg	50.0 Kg

The maximum flow rate will give a pressure drop of approximately 3" water gauge (5.61mm Hg) across the dryer.

The above figures are based on use in a temperate climate. Please consult our technical staff for guidance on the use of these units in tropical or unusual conditions.

Installation Methods

Installing a unit as a Tank Vent Dryer

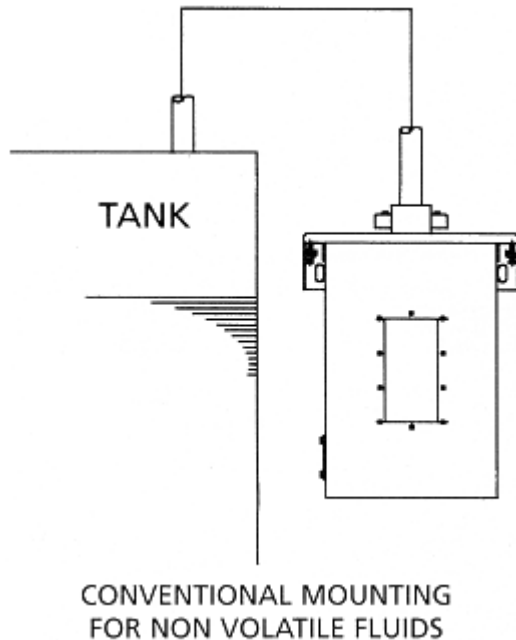

Tank Vent Dryer bypass arrangement schematic

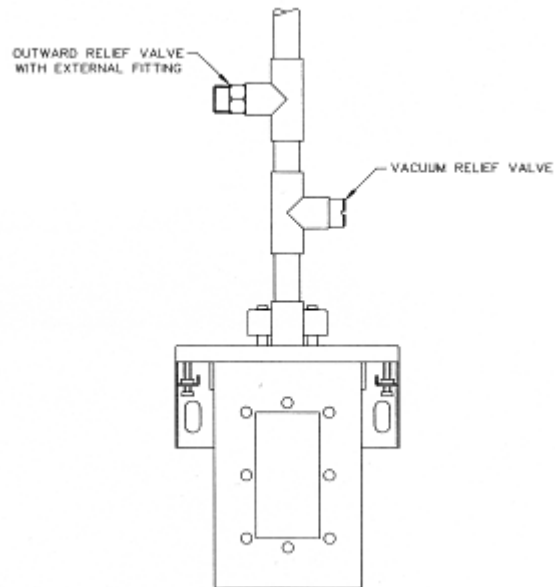

Wall mounted versions: Models 605, 610 and 615.

Floor mounted versions: Models 620 and 630.

All dryers should be positioned out of the direct rays of the sun and on the coolest side of the tank. This is necessary because high temperatures cause a loss of adsorption capacity, thus reducing the efficiency of the silica gel desiccant.

Floor mounted versions should be positioned so that the atmospheric air intake under the dryer cannot be blocked with debris of any kind.

If a tank vent dryer is fitted to a storage tank which contains harmful vapours, it will be necessary to pipe the exhaust from the dryer through a contaminant filter before allowing the gas to vent to atmosphere.

Installation instructions for standard Tank Vent Dryers - no harmful vapours exhausted.

1. Depending upon the model size, mount the unit either on a wall adjacent to the tank or on the ground nearby.
2. Remove the sealing plug from the threaded connector on top of the dryer and the self adhesive metal foil barrier from the base. **Caution:** ensure the self adhesive metal foil barrier is removed from the base of the unit before putting the unit into operation.
3. Connect the unit to the inlet vent of the tank using flexible water vapour proof tubing or steel piping. **Caution:** should the replenishment rate of the storage vessel exceed the tank vent dryer capacity an outward relief valve should be fitted.

Please contact our technical staff for details of pipe work and non-return valve arrangements for removal units handling volatile contaminants.



Operation

Periodic inspection should be carried out to monitor the condition of the desiccant charge. The dryers are filled with beaded Envirogel desiccant. This material changes colour from orange to green as it becomes saturated with water vapour. When the colour change reaches the indicator line on the desiccant container it should be recharged with fresh desiccant.

Maintenance

The only maintenance necessary to keep the dryer in a fully active condition is the replacement of the spent desiccant as detailed below.

1. Loosen the clamping screws or bolts, located on the under side of the mounting frame at the top of the unit, until the desiccant container rests on the support guides,
 2. Withdraw the complete desiccant container from the guide rails.
 3. Either replace the complete sub-assembly with a new unit or empty the saturated desiccant from the container. An emptying point is provided on the side of the container, except for 605 models. The spent desiccant may be disposed of in a normal landfill site.
 4. Remove the rubber diaphragm and cover plate from the top of the container. Refill with fresh desiccant and refit cover plate and rubber diaphragm.
 5. Slide the desiccant container into the mounting frame along the guide rails and tighten the clamping screws or bolts.
-

Desiccant Refills

Envirogel refills – Part No: BL/D6331 offers capacities ranging from 0.5 to 50Kg.

**Adsorbents**

Alternative types of adsorbents are available to remove other harmful contaminants other than water vapour.

Typical Adsorbents Used	
<ul style="list-style-type: none"> • Molecular Sieves • Activated Carbon 	<ul style="list-style-type: none"> • Silica Gel • Soda Lime

Typical Contaminants		
<ul style="list-style-type: none"> • Acetone • Acid • Ammonia • Carbon Dioxide • Carbon Monoxide 	<ul style="list-style-type: none"> • Ethylene • Formaldehyde • Freon • Hydrogen • Oil Vapours 	<ul style="list-style-type: none"> • Oxides of Nitrogen • Sulphide • Sulphur Dioxide • Toluene

Typical materials which can be readily protected	
<ul style="list-style-type: none"> • Acetic Acid • Arklone • Brake Fluid • Ethanolamine • Genklene • Glycerol • Methylmethacrylate 	<ul style="list-style-type: none"> • Perklone • Polyalcohols • Polythers • Sulphuric Acid • Transformer Oils • Trichlorethylene • Triklone

This data is supplied for information purposes only and is subject to change without prior notification

Please contact Brownell Limited for any further information or guidance required.

Tel: 020 8965 9281

Fax: 020 8965 3239

E-mail: info@brownell.co.uk



Humidity Control and Moisture Protection

Unit 2 Abbey Road Industrial Park, Commercial Way,
Park Royal, London, NW10 7XF